



US008729789B2

(12) **United States Patent**
Hasegawa

(10) **Patent No.:** **US 8,729,789 B2**
(45) **Date of Patent:** **May 20, 2014**

- (54) **DISPLAY APPARATUS**
- (75) Inventor: **Toshinori Hasegawa**, Yokohama (JP)
- (73) Assignee: **Canon Kabushiki Kaisha**, Tokyo (JP)

7,915,812 B2	3/2011	Hasegawa	
8,004,189 B2	8/2011	Hasegawa et al.	
2009/0079336 A1*	3/2009	Yamada et al.	313/504
2009/0115315 A1	5/2009	Takaya et al.	
2011/0024736 A1*	2/2011	Kambe et al.	257/40

(*) Notice: Subject to any disclaimer, the term of this patent is extended or adjusted under 35 U.S.C. 154(b) by 301 days.

FOREIGN PATENT DOCUMENTS

JP	2004-39500 A	2/2004
JP	2009-49135 A	3/2009
JP	2010003577 A	1/2010

(21) Appl. No.: **13/295,429**

(22) Filed: **Nov. 14, 2011**

(65) **Prior Publication Data**
US 2012/0133575 A1 May 31, 2012

OTHER PUBLICATIONS

Chinese Office Action issued in counterpart application No. 201110390533.1 dated Jan. 8, 2014, along with its English-language translation—11 pages.

(30) **Foreign Application Priority Data**
Nov. 30, 2010 (JP) 2010-266660
Oct. 31, 2011 (JP) 2011-238493

* cited by examiner

Primary Examiner — Mary Ellen Bowman
(74) *Attorney, Agent, or Firm* — Fitzpatrick, Cella, Harper & Scinto

- (51) **Int. Cl.**
H01L 51/50 (2006.01)
- (52) **U.S. Cl.**
USPC **313/501**; 313/504; 313/506
- (58) **Field of Classification Search**
USPC 313/504, 506, 501
See application file for complete search history.

ABSTRACT

(57) Provided is a display apparatus, which has both high light-emission efficiency and good display performance. The display apparatus includes multiple pixels, each of the multiple pixels including an organic light-emitting device including a first electrode, a light-emitting layer, and a second electrode, the multiple pixels including an optical unit for allowing a part of light emitted from the light-emitting layer to exit to outside while changing an exiting direction thereof, in which, in the multiple pixels including the optical unit, an optical distance between the light-emitting layer and the first electrode or an optical distance between the light-emitting layer and the second electrode is set to a predetermined value.

- (56) **References Cited**
U.S. PATENT DOCUMENTS
7,538,487 B2 5/2009 Hasegawa et al.
7,750,563 B2 7/2010 Hasegawa

3 Claims, 2 Drawing Sheets

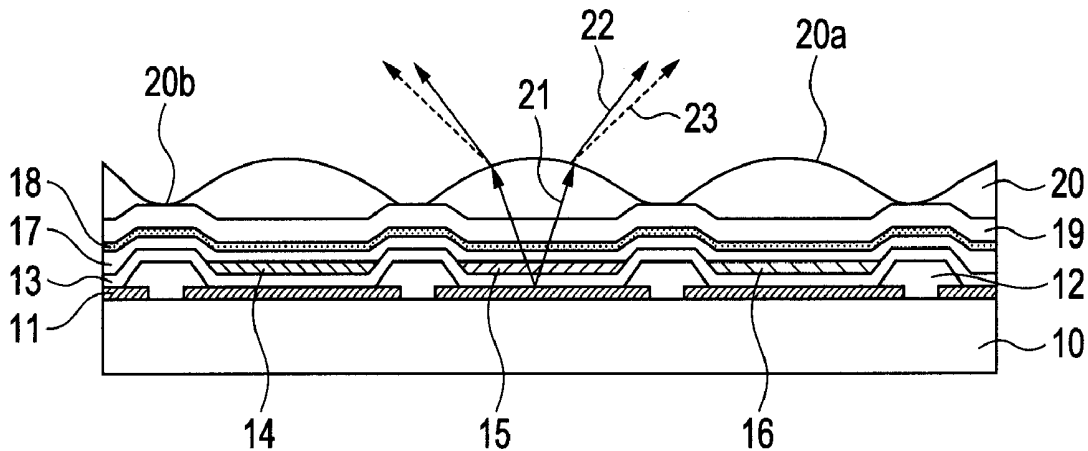

FIG. 1

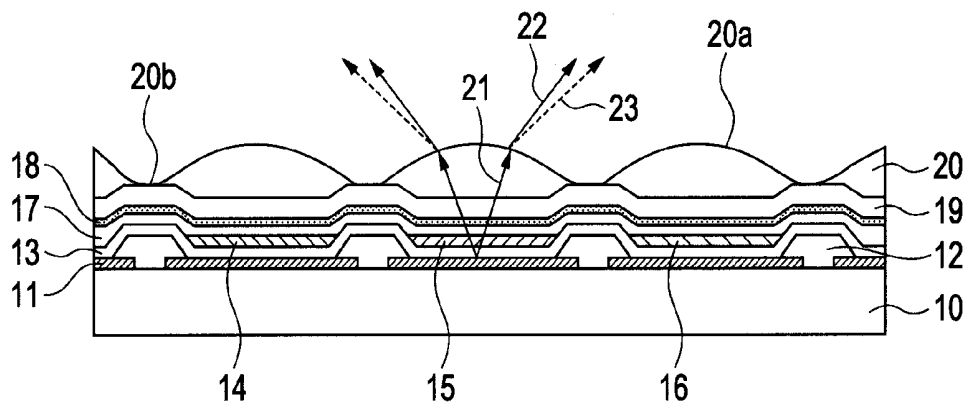

FIG. 2

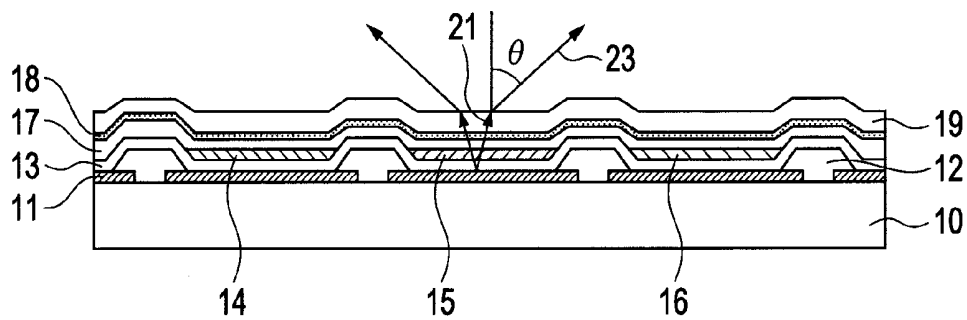

FIG. 3A

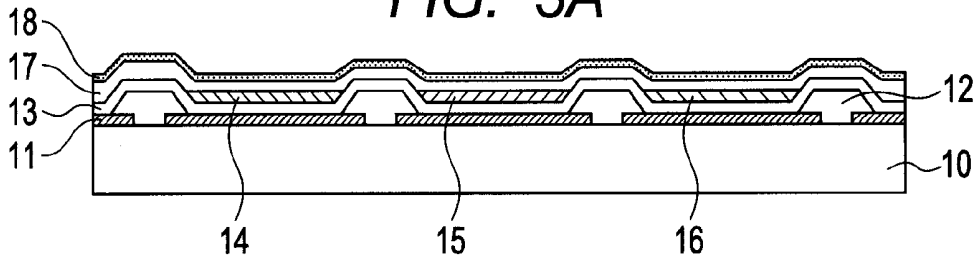

FIG. 3B

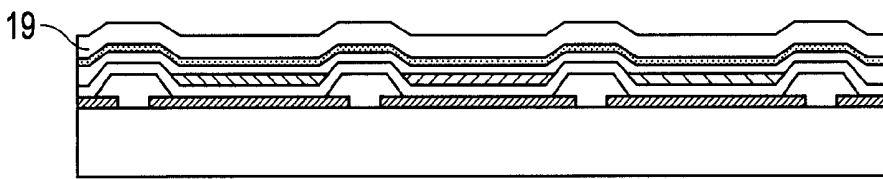

FIG. 3C

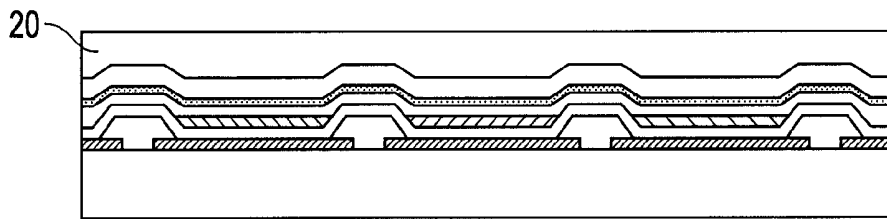

FIG. 3D

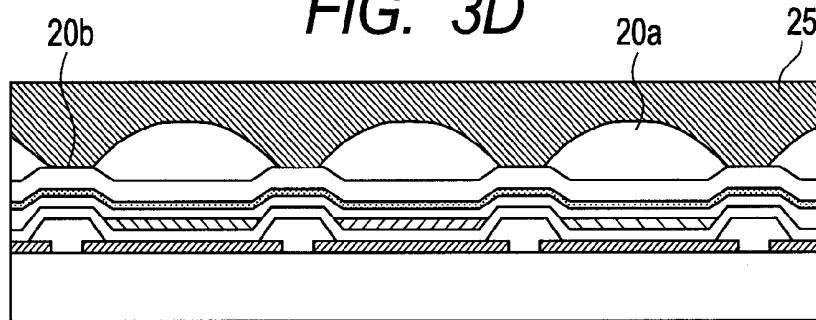
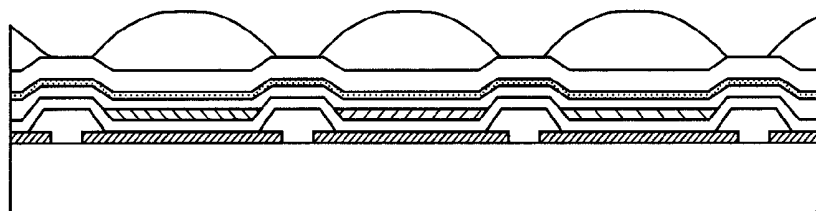

FIG. 3E



DISPLAY APPARATUS

BACKGROUND OF THE INVENTION

1. Field of the Invention

The present invention relates to a display apparatus using organic light-emitting devices (organic electroluminescence (EL) devices).

2. Description of the Related Art

In recent years, a display apparatus using organic light-emitting devices for displaying multiple different emission colors has attracted attention as a display apparatus replacing conventional CRTs and LCDs. Each of the organic light-emitting devices is a spontaneous emission device which includes multiple organic compound layers including a light-emitting layer interposed between an anode and a cathode. Therefore, the display apparatus using the organic light-emitting devices exhibits excellent performance in terms of contrast and color reproducibility.

The organic light-emitting device is a thin-film light-emitting device in which multiple thin films having different functions are laminated. For this structure, a light confinement effect is generated due to a total reflection effect which is characteristic to the thin-film light-emitting device. Therefore, emitted light, which can be extracted to the outside of the device, of light generated inside the device is only about 20 to 30%. Therefore, the thin-film light-emission device has a problem in that efficiency of extracting emitted light to the outside is low.

In order to solve the problem described above, for example, a display apparatus in which a microlens is provided on an emission extracting surface side of an organic light-emitting device to enable the efficient extraction of emitted light to the outside of the device is proposed (see Japanese Patent Application Laid-Open No. 2004-039500).

In the technology described in Japanese Patent Application Laid-Open No. 2004-039500, a method for improving the light-emission efficiency by the microlenses is described. However, display performance in terms of color reproducibility when the organic light-emitting devices provided with the microlenses are used for the display apparatus has not been examined.

SUMMARY OF THE INVENTION

In view of the problems described above, the present invention has an object to provide a display apparatus using organic light-emitting devices provided with a microlens, which has both high light-emission efficiency and good display performance.

A structure of the present invention made to achieve the aforementioned object is as follows.

That is, a display apparatus according to the present invention includes multiple pixels, each of the multiple pixels including an organic light-emitting device including a first electrode, a light-emitting layer, and a second electrode, the multiple pixels including an optical unit for allowing a part of light emitted from the organic light-emitting device to exit to outside while changing an exiting direction thereof, in which, in the multiple pixels, an optical distance L_1 between a light-emission position of the organic light-emitting device and the first electrode and an optical distance L_2 between the light-emission position and the second electrode satisfy Expressions below:

$$2L_1/\lambda + \phi_1/2\pi = 1; \text{ and}$$

$$L_2 > 0, \text{ and } 2L_2/\lambda + \phi_2/2\pi < 1,$$

where λ is a maximum peak wavelength of a spectrum of light emitted from the organic light-emitting device, ϕ_1 is a phase shift occurring when the light emitted at the light-emission position is reflected by the first electrode, and ϕ_2 is a phase shift occurring when the light emitted at the light-emission position is reflected by the second electrode.

According to the present invention, the organic light-emitting device is set with the lowest-order of optical interference. Therefore, light emitted with high color purity can be extracted with good color reproducibility by the optical unit to the outside of the display apparatus. Therefore, an excellent effect of providing the display apparatus having both high light-emission efficiency and good display performance is exerted.

Further features of the present invention will become apparent from the following description of exemplary embodiments with reference to the attached drawings.

BRIEF DESCRIPTION OF THE DRAWINGS

FIG. 1 is a partial sectional view illustrating a layer structure of a display apparatus according to an embodiment of the present invention.

FIG. 2 is a partial sectional view illustrating a layer structure of a conventional display apparatus.

FIGS. 3A, 3B, 3C, 3D and 3E are explanatory views illustrating manufacturing steps of the display apparatus according to the embodiment of the present invention.

DESCRIPTION OF THE EMBODIMENTS

Hereinafter, an embodiment of the present invention is described referring to the accompanying drawings. However, the present invention is not limited to this embodiment. To a part which is not particularly illustrated or described in this specification, known or common technologies in the technical field are applied.

(Configuration of Display Apparatus)

First, referring to FIG. 1, an embodiment of a display apparatus according to the present invention is described. FIG. 1 is a partial sectional view illustrating a layer structure of the display apparatus according to the embodiment of the present invention, whereas FIG. 2 is a partial sectional view illustrating a layer structure of a conventional display apparatus.

As illustrated in FIG. 1, the display apparatus according to this embodiment is a top-emission type display apparatus in which light is extracted from an upper surface of an organic light-emitting device formed on a substrate **10**.

The display apparatus according to this embodiment includes the substrate **10** and multiple pixels formed in matrix on the substrate **10**. The multiple pixels constitute a display region. The pixel herein means a region corresponding to one light-emitting device. In this embodiment, the display apparatus which includes the organic light-emitting devices emitting red (R) light, green (G) light, and blue (B) light formed respectively in the multiple pixels is described as an example. Colors of light emission of the display apparatus are not particularly limited as long as the number of colors is at least two, and the organic light-emitting device emitting light of any color can be used.

A pixel isolation layer **12** for isolating the pixels from each other is provided between the organic light-emitting devices. Each of the organic light-emitting devices is provided between an anode electrode **11** and a cathode electrode **18**. Between the pair of electrodes **11** and **18**, a hole injection/transport organic compound layer **13**, a pattern layer **14**

including a red-light-emitting layer, a pattern layer **15** including a green-light-emitting layer, a pattern layer **16** including a blue-light-emitting layer, and an electron injection/transport organic compound layer **17** are provided. Hereinafter, the pattern layers **14** to **16** are referred to simply as the light-emitting layers **14** to **16**. More specifically, the anode electrode **11** patterned for each pixel is formed on the substrate **10**. On the anode electrode **11**, the hole injection/transport organic compound layer **13** and the light-emitting layers **14** to **16** are formed. On the light-emitting layers **14** to **16**, the electron injection/transport organic compound layer **17** is formed. Further, the cathode electrode **18** is formed thereon.

The anode electrode (first electrode) **11** is made of an electrically conductive metal material having high reflectance, for example, Ag or the like. The anode electrode **11** may be formed of a laminate including a layer made of the metal material as described above and a layer made of a transparent electrically-conductive material such as indium-tin-oxide (ITO) excellent in hole injection properties.

Meanwhile, the cathode electrode (second electrode) **18** is formed commonly to the multiple organic light-emitting devices. The cathode electrode **18** has a structure with a semi-reflective property or a light-transmitting property, which allows the light emitted from the light-emitting layers **14** to **16** to be extracted to the outside of the device. More specifically, when the cathode electrode **18** has the structure with the semi-reflective property in order to enhance an interference effect inside of the device, a layer made of an electrically-conductive metal material excellent in electron injection properties such as Ag and AgMg is formed to have a thickness of 2 to 50 nm to form the cathode electrode **18**. The term "semi-reflective property" means a property of reflecting a part of the light generated inside and emitted from the device and transmitting the other part of the emitted light, and has a reflectance of 20 to 80% with respect to visible light. The term "light-transmitting property" means a property with a transmission rate of 80% or higher with respect to the visible light.

The hole injection/transport organic compound layer **13** is formed of a single layer or multiple layers made of an organic compound having hole injection and transport properties. As an example of a structure of the hole injection/transport organic compound layer **13**, for example, a single layer of a hole injection layer, a single layer of a hole transport layer, or a laminate structure of the hole injection layer and the hole transport layer is given. As a material for forming the hole injection/transport organic compound layer **13**, a known material can be used.

The material of each of the light-emitting layer **14** for emitting red light, the light-emitting layer **15** for emitting green light, and the light-emitting layer **16** for emitting blue light is not particularly limited, and a known material can be used. For example, a single layer made of a material having both a luminescent property and a carrier transport property or a layer made of a mixture of a host material having a carrier transport property and a luminescent material such as a fluorescent material or a phosphorescent material can be used.

The electron injection/transport organic compound layer **17** is formed of a single layer or multiple layers made of an organic compound having electron injection/transport properties. As an example of a structure of the electron injection/transport organic compound layer **17**, for example, a single layer of an electron injection layer, a single layer of an electron transport layer, or a laminate structure of the electron injection layer and the electron transport layer is given. As a material for forming the electron injection/transport organic compound layer **17**, a known material can be used.

Pixel circuits are formed on the substrate **10** so as to be able to independently drive each of the organic light-emitting devices. The pixel circuits are formed of a plurality of transistors (not shown). The substrate **10**, on which the transistors are formed, is covered with an interlayer insulating film (not shown) through which contact holes for electrically connecting the transistors and the anode electrodes **11** to each other are formed. On the interlayer insulating film, a planarizing film (not shown) for absorbing unevenness of a surface due to the formation of the pixel circuits to level the surface is formed.

On the cathode electrode **18**, a protective layer **19** for protecting the organic light-emitting devices from oxygen or water contained in air is formed.

On a light-extracting side (upward direction of FIG. 1) of the protective layer **19**, multiple microlenses **20a** are formed in array as an optical unit. The microlenses **20a** have a light-condensing effect for changing an exiting direction of at least a part of the light generated in the light-emitting layers and allowing the light to exit to the outside.

The microlenses **20a** are formed by, for example, processing a resin material. More specifically, the microlenses **20a** can be formed by a method such as embossing. A light-condensing effect of the microlenses **20a** depends on a light-emitting area, a curvature of each of the microlenses, and a distance from a light-emitting surface to the microlens. Thus, it is preferred to design the microlenses by using the aforementioned elements as parameters. The dependence of the light-emitting area and the light-condensing property can be described as follows. Specifically, light emitted immediately under the center of the microlens is likely to condense in a front direction, whereas light emitted immediately below the periphery of the microlens is unlikely to condense in the front direction. The microlenses can also be formed by photolithography. Alternatively, the microlenses may be formed by the following method. A photosensitive material used as a microlens material is patterned by photolithography and is then reflowed by annealing to form a lens shape. Further alternatively, the photosensitive material may be directly formed into a lens shape by photolithography with a grey mask. Further alternatively, after a resist is applied onto the microlens material and is processed into the lens shape, the lens shape of the resist may be transferred to the microlens material by anisotropic etching. Further alternatively, after the microlenses are processed on another substrate, the thus processed microlenses may be bonded to the light-emitting devices.

The term "light condensing" herein means that light is condensed as compared with an exiting property of a light ray on a flat light-extracting surface on which the microlens is not present. As in the case of a normal lens, light emitted at a position which is situated shorter than a focal length is diffused even through a condensing lens as compared with parallel light. Even in this case, however, the light is refracted in the light-condensing direction as compared with the case where the microlens is not provided.

Although it is preferred to form the microlens **20a** independently for each pixel (equivalent to the organic light-emitting device), multiple microlenses may be formed for one pixel, or one microlens may be formed for the multiple pixels. Moreover, depending on the shape of each of the microlenses **20a**, a protective layer may be formed thereon.

(Effects and Interference Conditions of Display Apparatus)

With the configuration as described above, for example, when one microlens **20a** is provided for one pixel, the light emitted from the organic light-emitting device is transmitted

through the cathode electrode 18. Subsequently, the light is transmitted through the protective layer 19 and a microlens array 20 and is then emitted to the outside of the organic light-emitting device.

In the case where the microlenses 20a are not formed (see FIG. 2), light 21 emitted obliquely from the light-emitting layer exit at a wider angle (in a direction indicated by the arrows 23) when exiting from the protective layer 19. On the other hand, as illustrated in FIG. 1, with the configuration including the microlenses 20a, the exiting angle of lights 22, which are transmitted through the microlens and are then emitted to the outside, becomes closer to a vertical direction with respect to the substrate (in a direction indicated by the arrows 22) as compared with the case where the microlenses 20a are not provided. Therefore, as compared with the case where the microlenses 20a are not present, the light-condensing effect in the vertical direction with respect to the substrate is improved in the case where the microlenses 20a are present. Specifically, as the display apparatus, light utilization efficiency in the front direction can be enhanced.

With the configuration including the microlenses 20a, an incident angle of light beams 21 emitted obliquely from the light-emitting layer on an exiting interface (boundary between the lens 20a and the outside) becomes closer to be vertical due to the curvature of the lens. Therefore, the amount of light totally reflected at the interface is reduced to allow a larger amount of emitted light to be extracted to the outside of the display apparatus. Specifically, the light extracting efficiency is also improved.

Subsequently, optical interference conditions of the organic light-emitting device in the display apparatus according to this embodiment are described. In general, a thickness of each of the layers constituting each of the organic light-emitting devices is about several tens of nm. An optical distance obtained by multiplying a thickness (d) of each layer and a refractive index (n) of the corresponding layer (product of n and d) corresponds to about a fraction of a wavelength of visible light ($\lambda=350$ nm or longer and 780 nm or shorter). Therefore, inside the organic light-emitting device, multiple reflection and interference of the visible light occur in a noticeable manner. Therefore, the wavelength λ enhanced by the interference effect (enhancing wavelength λ due to the optical interference) is defined as expressed by Expression (1) below. Specifically, the enhancing wavelength λ is defined by structure parameters of the light-emitting device such as an optical distance L_1 between a light-emission position and the first electrode and a phase shift ϕ_1 occurring when the light is reflected by the first electrode, and an order m_1 of the optical interference. The enhancing wavelength λ due to the optical interference is a maximum peak wavelength of a spectrum of the light extracted from the optical light-emitting device.

$$\lambda = 2L_1 \cos \theta / (m_1 - \phi_1 / 2\pi) \quad (m_1 \text{ is a positive integer, and } \theta \text{ is a radiation angle of light emission}) \quad (1)$$

In front, specifically, at the radiation angle θ of 0 degrees, Expression (2) below is established.

$$2L_1 / \lambda + \phi_1 / 2\pi = m_1 \quad (2)$$

Among the two materials forming the interface, it is assumed that a material present on the light entering side is a medium I and the other material is a medium II and optical constants thereof are (n_I, k_I) and (n_{II}, k_{II}) , respectively. Then, the phase shift ϕ_1 at the interface can be expressed by Expression (3) below. The optical constants can be measured by using, for example, a spectroscopic ellipsometer or the like.

$$\phi_1 = 2\pi - \tan^{-1}(2n_I k_{II} / (n_I^2 - n_{II}^2 - k_{II}^2)) \quad (3)$$

The light emitted from the organic light-emitting device corresponds to emitted light released after the recombination of carriers inside the light-emitting layer, on which the optical interference effect is superimposed. Therefore, if the optical distance or the phase shift of each layer is changed, the enhancing wavelength according to Expression (1) or (2) also changes. Thus, the light-emitting characteristics of the organic light-emitting device can be adjusted.

First, optical interference conditions between the anode electrode 11 and the light-emission position of the organic light-emitting device included in the display apparatus according to this embodiment are described. When the interference of light emission occurs between the anode electrode 11 and the light-emission position, the case where the emitted light is reflected by the anode electrode 11 is considered for a phase shift amount. An actual measurement using an Al alloy allows the phase shift amount to be estimated as 3.84 (rad) (220.0 degrees) according to Expression (3) above. In the description of the specification of the present invention, the phase shift is described using 3.84 (rad) (220.0 degrees). However, the phase shift greatly depends on the metal material and further changes depending on a formation method and a formation apparatus. Therefore, for precision, it is necessary to actually measure the optical characteristics of the film formed in the apparatus to be used to calculate the phase shift.

In order to set the enhancing wavelength to 460 nm at the light emission radiation angle of 0 degrees (angle from a normal direction to the substrate), the optical distance L_1 between the anode electrode 11 and the light-emission position is set to 89 nm with $m_1=1$, 319 nm with $m_1=2$, and 549 nm with $m_1=3$ according to Expression (2) above. By Expression (1) above, the enhancing wavelength differs depending on the light emission radiation angle. Tables 1, 2, and 3 show the relation between the radiation angle and the enhancing wavelength at each of the optical distances.

TABLE 1

Optical distance 89 nm			
Radiation angle	$m_1 = 1$	$m_1 = 2$	$m_1 = 3$
0°	460 nm	129 nm	75 nm
5°	458 nm	128 nm	75 nm
10°	453 nm	127 nm	74 nm
15°	444 nm	124 nm	72 nm
20°	432 nm	121 nm	70 nm
25°	417 nm	117 nm	68 nm
30°	398 nm	112 nm	65 nm
35°	377 nm	105 nm	61 nm
40°	352 nm	99 nm	57 nm
45°	325 nm	91 nm	53 nm
50°	296 nm	83 nm	48 nm
55°	264 nm	74 nm	43 nm
60°	230 nm	64 nm	37 nm
65°	194 nm	54 nm	32 nm
70°	157 nm	44 nm	26 nm
75°	119 nm	33 nm	19 nm
80°	80 nm	22 nm	13 nm
85°	40 nm	11 nm	7 nm
90°	—	—	—

TABLE 2

Optical distance 319 nm			
Radiation angle	m ₁ = 1	m ₁ = 2	m ₁ = 3
0°	1,643 nm	460 nm	267 nm
5°	1,637 nm	458 nm	266 nm
10°	1,618 nm	453 nm	263 nm
15°	1,587 nm	444 nm	258 nm
20°	1,544 nm	432 nm	251 nm
25°	1,489 nm	417 nm	242 nm
30°	1,423 nm	398 nm	232 nm
35°	1,346 nm	377 nm	219 nm
40°	1,259 nm	352 nm	205 nm
45°	1,162 nm	325 nm	189 nm
50°	1,056 nm	296 nm	172 nm
55°	943 nm	264 nm	153 nm
60°	822 nm	230 nm	134 nm
65°	694 nm	194 nm	113 nm
70°	562 nm	157 nm	91 nm
75°	425 nm	119 nm	69 nm
80°	285 nm	80 nm	46 nm
85°	143 nm	40 nm	23 nm
90°	—	—	—

TABLE 3

Optical distance 549 nm			
Radiation angle	m ₁ = 1	m ₁ = 2	m ₁ = 3
0°	2,827 nm	791 nm	460 nm
5°	2,816 nm	788 nm	458 nm
10°	2,784 nm	779 nm	453 nm
15°	2,730 nm	764 nm	444 nm
20°	2,656 nm	744 nm	432 nm
25°	2,562 nm	717 nm	417 nm
30°	2,448 nm	685 nm	398 nm
35°	2,315 nm	648 nm	377 nm
40°	2,165 nm	606 nm	352 nm
45°	1,999 nm	559 nm	325 nm
50°	1,817 nm	509 nm	296 nm
55°	1,621 nm	454 nm	264 nm
60°	1,413 nm	396 nm	230 nm
65°	1,195 nm	334 nm	194 nm
70°	967 nm	271 nm	157 nm
75°	732 nm	205 nm	119 nm
80°	491 nm	137 nm	80 nm
85°	246 nm	69 nm	40 nm
90°	—	—	—

According to Tables 1, 2, and 3, as the radiation angle and the m₁ value increase, the enhancing wavelength is shifted to be shorter as compared with the enhancing wavelength of the emitted light radiated in the front direction of the device.

Next, the angle (radiation angle) of the emitted light entering the microlenses 20a is considered. In this embodiment, the microlenses 20a are formed on the protective layer 19. As the material of the protective layer 19, an inorganic compound such as, for example, silicon nitride is used to protect the organic light-emitting device from oxygen and water contained in air. Moreover, the microlenses 20a are mainly formed of a resin material. Therefore, the protective layer 19 and the microlenses 20a have a difference in refractive index. In general, the inorganic compound such as silicon nitride has a higher refractive index than that of the resin material. Thus, total reflection occurs at the interface between the protective layer 19 and each of the microlenses 20a. A critical angle θ_c at which the total reflection occurs can be calculated according to Expression (4) described below using a refractive index n₁ of the protective layer 19 and a refractive index n₂ of the microlenses 20a.

$$\theta_c = \sin^{-1}\left(\frac{n_2}{n_1}\right) \quad (4)$$

For example, supposing that the refractive index of the protective layer 19 is 1.80 and the refractive index of the microlens 20a is 1.68, the critical angle is 69 degrees. Therefore, of all the light generated in and emitted from the organic light-emitting device, light at the radiation angle up to 69 degrees enters the microlens 20a. In the case where the emitted light is allowed to directly exit from the protective layer 19 to the outside of the display apparatus without providing the microlenses 20a, the critical angle is about 34 degrees according to Expression (4) above with n₁=1.80 (refractive index of the protective layer) and n₂=1.00 (refractive index of air) when a refractive index of an external environment is 1. Specifically, the light emission at the radiation angle ranging from 34 to 69 degrees, which cannot be used in the display apparatus without the microlens, can be used by providing the microlenses 20a. The thus enhanced light utilization efficiency of the light emission is one of the advantages of providing the microlenses.

When glass-cap sealing is used, the protective layer is not indispensable under the microlens 20a and therefore, the total reflection due to the difference in refractive index from the light-emitting layer to the microlens can be suppressed. In this case, the light reaches over the entire dimensional area of the microlens 20a.

The light reaching the microlens can be extracted to the outside depending on the angle of the boundary between the microlenses and the outside by microlens design.

When the critical angle at which the light can enter the microlens from the protective layer is set to 69 degrees, the difference in refractive index between the organic compound layer and the protective layer is small, and therefore the radiation angles shown in Tables 1, 2, and 3 are approximately replaced by the radiation angle in the protective layer provided on the cathode electrode. Assuming the optical distance of the organic light-emitting device is 89 nm in the display apparatus including the microlens, the enhancing wavelength of the emitted light entering the microlens 20a correspond to the values at the radiation angle of 0 degrees to the vicinity of 70 degrees described in Table 1. The enhancing wavelength is 460 nm to 157 nm when m₁=1, 129 nm to 44 nm when m₁=2, and 75 nm to 26 nm when m₁=3. In general, a wavelength range of the visible light visually recognized by the human eye is from 380 nm to 780 nm. Therefore, the light emission recognized by an observer of the display apparatus in the case where the optical distance L₁ of the organic light-emitting device is set to 89 nm is mainly limited to the enhanced light emission which satisfies the condition m₁=1. The enhancing wavelength of the light entering the microlens under the condition of m₁=2 or m₁=3 corresponds to an enhancing condition for the light at a wavelength other than a visible wavelength. The organic light-emitting device used for the display apparatus generally includes the light-emitting layer which emits the light in the visible wavelength range. Therefore, the wavelength enhancing conditions such as m₁=2 and m₁=3 do not affect the light-emitting characteristics of the organic light-emitting device. Therefore, the light-emitting characteristics of the organic light-emitting device are determined by the optical interference conditions with m₁=1.

Subsequently, assuming that the optical distance of the organic light-emitting device is 319 nm, the enhancing wavelength of the emitted light entering the microlens 20a correspond to the values at the radiation angle of about 0 degrees to

the vicinity of 70 degrees shown in Table 2. The enhancing wavelength is 1,643 nm to 562 nm when $m_1=1$, 460 nm to 157 nm when $m_1=2$, and 267 to 91 nm when $m_1=3$. In this case, it is the light emission enhanced under the condition $m_1=2$ and the light emission enhanced at the radiation angle of about 65 degrees to 70 degrees under the condition $m_1=1$ that affect the light emission in the visible wavelength range. The light emission enhanced under the condition $m_1=1$ has a longer wavelength than the enhancing wavelength of 460 nm under the condition $m_1=2$ in front of the display apparatus.

Assuming the optical distance of the organic light-emitting device is 549 nm, the enhancing wavelength of the emitted light entering the microlens 20a is the same as those shown in Table 3. The enhancing wavelength is 2,827 nm to 967 nm when $m_1=1$, 791 nm to 271 nm when $m_1=2$, and 460 nm to 157 nm when $m_1=3$. In this case, it is the light emission enhanced under the condition $m_1=3$ and the light emission enhanced at the radiation angle of 5 degrees to 60 degrees under the condition $m_1=2$ that affect the light emission in the visible wavelength range. Of the aforementioned light, the light emission enhanced at the radiation angle of 25 degrees to 50 degrees under the condition $m_1=2$ has a longer wavelength than the enhancing wavelength 460 nm under the condition $m_1=3$ in front of the display apparatus.

As described above, although the enhancing wavelength in front of the display apparatus is the same, that is, 460 nm, the enhancing wavelength of the emitted light entering the microlenses 20a varies depending on the optical distance of the organic light-emitting device. Table 4 collectively shows wavelength ranges corresponding to the visible-light wavelength range among the aforementioned emitted light entering the microlenses 20a.

TABLE 4

		$m_1 = 1$	$m_1 = 2$	$m_1 = 3$
Optical distance 89 nm	Upper limit	460 nm	—	—
	Lower limit	398 nm	—	—
Optical distance 319 nm	Upper limit	694 nm	460 nm	—
	Lower limit	562 nm	398 nm	—
Optical distance 549 nm	Upper limit	—	789 nm	460 nm
	Lower limit	—	396 nm	398 nm

In comparison between the aforementioned three display apparatuses, the display apparatus having the shortest optical distance of 89 nm has a narrow enhancing wavelength range of the emitted light entering the microlenses 20a as compared with the other display apparatuses. Further, in terms of the relation between the optical interference effect and the order m_1 , it is known that the enhancing effect due to the optical interference is generally higher as the order m_1 becomes smaller. Therefore, the organic light-emitting devices with $m_1=2$ and $m_1=3$ shown in Tables 2 and 3 satisfy the interference conditions of lower orders at the same time. Therefore, a stronger enhancing effect is generated at a longer wavelength than that in front of the display apparatus. In the display apparatus described above, light having a wider variety of wavelengths and intensities enters the microlens as compared with the display apparatus with the order $m_1=1$. Therefore, color purity of the light emission is lowered. Further, interference of the lower orders also appears at an oblique viewing angle. Therefore, color changes in a complex manner.

Therefore, for the display apparatus of this embodiment, the optical distance between the light-emission position and the first electrode is set so as to satisfy the condition $m_1=1$ in Expression (2). In this manner, the display apparatus having

high color purity of the light emission and good color reproducibility can be realized. Specifically, the optical distance L_1 between the light emission position and the first electrode is set to satisfy Expression (5) below.

$$2L_1/\lambda + \phi_1/2\pi = 1 \quad (5)$$

where ϕ_1 is a phase shift occurring when the emitted light is reflected by the first electrode, and λ is a maximum peak wavelength of a spectrum of the light extracted from the organic light-emitting device.

The enhancing effect due to the higher optical interference effect can be used by setting the optical distance of the organic light-emitting device under the condition $m_1=1$ as compared with the case where the optical distance is set under the condition $m_1>1$ when the same enhancing wavelength is to be set. Therefore, an advantage of improving the light-emission efficiency of the organic light-emitting device can be realized at the same time. In this manner, the display apparatus with high color purity of the light emission, which performs brighter display, that is, has good color reproducibility at a low power consumption, can be realized.

In the description of this embodiment, the optical distance between the anode electrode 11 and the light-emission position has been dealt with. However, when the light-emission region has an extent or a distribution inside the light-emitting layer, the optical distance is appropriately adjusted so as to satisfy the interference conditions in view of the distribution of the light-emitting region inside the light-emitting layer.

Moreover, in view of the case where the thickness of the organic compound layer varies when the film is formed, the optical distance L_1 may be offset from a value satisfying Expression (5) by an extremely small value. More specifically, the effects of the present invention can be obtained as long as Expression (5') is satisfied.

$$0.9 < 2L_1/\lambda + \phi_1/2\pi < 1.1 \quad (5')$$

As described above, the display apparatus of this embodiment is realized paying attention to a change in the enhancing effect caused by the angle dependence of the enhancing wavelength due to the critical angle at the interface at which the emitted light enters the microlens 20a and the optical interference, and the order of the optical interference. The optical distance of the optical light-emitting device constituting the display apparatus is set so as to satisfy the optical interference condition $m_1=1$ at a desired enhancing wavelength. In this manner, the color purity and the light-emission efficiency of the organic light-emitting device can be improved. Therefore, the display apparatus with good color reproducibility, which performs bright display at low power consumption, can be provided.

In the case where the microlens is not provided, the emitted light at an angle of up to 34 degrees is allowed to exit from the protective layer of the display apparatus to the outside. In this case, even though the optical distance is 319 nm, only the light with $m_1=2$ is visually recognized. Accordingly, the viewing-angle characteristics with good color can be obtained at both the optical distance of 89 nm and the optical distance of 319 nm.

The enhancing wavelength to be set is not particularly limited. The enhancing wavelength can be applied to any organic light-emitting device as long as the organic light-emitting device includes the light-emitting layer which emits light in the visible wavelength range. The enhancing wavelength can also be applied to an RGB three primary-color type display apparatus or a four primary-color type display apparatus for, for example, three primary colors plus cyan or yellow.

The optical interference conditions of this embodiment may be applied to all or part of the organic light-emitting devices constituting the display apparatus. Further, the optical interference conditions of this embodiment can be used differently for the respective light-emission colors. In particular, in the case of the blue-light-emitting device having a shorter emission wavelength, the enhancing wavelength to be set also becomes shorter. Therefore, the optical distance satisfying the optical interference condition becomes also shorter. For example, when the thickness of each layer of the organic light-emitting device is adjusted to reduce the optical distance, reliability or driving stability of the organic light-emitting device is sometimes lowered due to the reduction in thickness of the layer. In such a case, it is possible to use the interference condition $m_1 > 1$ for the blue-light-emitting device and the interference condition $m_1 = 1$ for the light-emitting devices for light emission of the other colors.

The optical interference conditions between the cathode electrode **18** and the light-emission position are described. In this case, the phase shift amount ϕ obtained when the emitted light is reflected by the cathode electrode **18** is considered. Supposing that the phase shift amount is ϕ_2, ϕ_1 in Expression (3) described above is replaced by ϕ_2 to obtain ϕ_2 . When the cathode electrode **18** is formed of an Ag thin film, the phase shift amount ϕ_2 is estimated to be 4.21 (rad) (241.4 degrees).

The cathode electrode **18** is a semi-transparent film located on the light exiting side. A reflectance of the cathode electrode **18** is about 40% at maximum although the reflectance depends on the thickness of the cathode electrode **18**. Therefore, in comparison with the interference condition on the side of the anode electrode **11** having a high reflectance of 70% or higher, the optical distance which less affects the light emission but satisfies various optical interference conditions can be set. In particular, preferably, the optical distance L_2 between the cathode electrode **18** and the light-emission position satisfies Expression (6) below for the maximum peak wavelength λ of the spectrum of the light emitted from the organic light-emitting device.

$$L_2 > 0, \text{ and } 2L_2/\lambda + \phi_2/2\pi < 1 \quad (6)$$

Specifically, the optical interference conditions between the cathode electrode **18** and the light-emission position are set so as to enhance a wavelength shorter than the enhancing wavelength on the anode electrode **11** side. For example, when the optical distance L_2 is set to 33.6 nm so as to satisfy Expression (6) in the organic light-emitting device having the wavelength of 520 nm, the optical interference condition of:

$$2L_2/\lambda + \phi_2/2\pi = 1$$

is satisfied based on the estimation from the phase shift amount 4.21 (rad). Specifically, light having the wavelength of 204 nm is to be enhanced. The optical interference condition is for enhancing light having a wavelength shorter than the light enhanced by the interference on the anode electrode **11** side.

As described above, the optical interference condition on the cathode electrode **18** side is set to the order of a value smaller than 1. In this manner, the enhancing wavelength range of the emitted light entering the microlens is further narrowed. As a result, the display apparatus having higher color purity can be realized.

Moreover, the setting of the short optical distance on the cathode electrode **18** side is preferred because a total optical distance between the anode electrode **11** and the cathode electrode **18** can be set short.

Moreover, in the present invention, a member for allowing the emitted light to exit to the outside of the display apparatus

is not particularly limited as long as the relation of angle dependence between the critical angle and the optical interference enhancing wavelength at the incident boundary with the member for allowing the emitted light to exit to the outside of the display apparatus is satisfied. Beside the microlens, the present invention is applicable when any members such as a prism-structured member, a concave-convex-structured member, and an anti-reflection member are provided.

(Steps of Manufacturing Display Apparatus)

Next, steps of manufacturing the display apparatus of this embodiment are described referring to FIGS. 3A to 3E. FIGS. 3A to 3E are explanatory views illustrating the steps of manufacturing the display apparatus of this embodiment. The manufacturing steps up to the formation of the cathode electrode **18** are known, and therefore the description thereof is herein omitted.

First, as illustrated in FIG. 3A, the substrate **10**, on which multiple top-emission type organic light-emitting devices are formed, is prepared. Each of the organic light-emitting devices includes the interlayer insulating film and the planarizing film formed on the substrate **10** on which the active matrix type pixel circuits are formed. Further, the anode electrode **11**, the pixel isolation layer **12**, the hole injection/transport organic compound layer **13**, the red-light-emitting layer **14**, the green-light-emitting layer **15**, the blue-light-emitting layer **16**, the electron injection/transport organic compound layer **17**, and the cathode electrode **18** are formed thereon.

Next, as illustrated in FIG. 3B, the first protective layer **19** is formed over the entire display region. The first protective layer **19** is a member having a so-called sealing function for preventing water contained in the resin material forming the second protective layer formed thereon from coming into contact with the organic light-emitting devices. For this function, it is preferred that the first protective layer **19** be a member having high light transmittance and excellent in moisture-proof property. It is therefore preferred that the first protective layer **19** be made of a silicon nitride film or a silicon nitride oxide film.

Next, as illustrated in FIG. 3C, the second protective layer **20** is formed on the first protective layer **19** over the entire display region. The second protective layer **20** is made of a resin material. A thickness of the second protective layer **20** is set to about 10 μm to 100 μm so that dust such as an etch residue can be sufficiently covered and that unevenness generated on the pixel isolation film **12** can be leveled. As the resin material, for example, a thermosetting resin, a thermoplastic resin, and a photocurable resin, which have a low water content, can be used. When a thermosetting resin or a photocurable resin is used, a spin coating method or a dispensing method can be used as a film formation method. Further, a method of bonding a film made of a thermoplastic resin, which has a thickness of about 10 μm to 100 μm , onto the first protective layer **19** under vacuum can also be used. As a specific resin material, for example, an epoxy resin and a butyl resin are suitably used.

Next, as illustrated in FIG. 3D, a mold **25** for forming the microlenses **20a** is prepared. The resin-material mold **25** is pressed against the resin material so that air bubbles do not enter the resin material. The shape of the mold **25** is changed for each light-emitting pixel of each color so as to adjust a light-condensing degree of the lens provided for each light-emitting pixel.

The mold **25** can be made of a general metal. When a photocurable resin is used as the resin material, it is preferred that the mold **25** be formed of a quartz substrate because the mold **25** is required to transmit light therethrough. Moreover, in order to enhance the removability of the mold **25** from the

resin material, a film made of a fluorine resin or the like may be formed on a surface of the mold **25**.

When a thermosetting resin is used as the resin material, the resin material is heated at 80° C. and cured in a state in which a top of a convex portion of each microlens of the mold **25** is approximately aligned with the center of the corresponding pixel. Considering that a withstand temperature of a general organic compound constituting the organic light-emitting device is about 100° C., a curing temperature of about 80° C. is preferred.

Next, as illustrated in FIG. 3E, the mold **25** is removed from the cured resin material. As a result, the microlenses **20a** are formed on the surface of the second protective layer **20** so as to respectively correspond to the pixels.

A protective layer may be provided on the microlenses **20a** as needed. In this case, it is preferred to design and process a surface shape of the mold **25** so as not to impair a sealing function of the protective layer formed on the microlenses **20a** and so as to allow the microlenses **20a** to demonstrate a desired light-condensing function.

As the protective layer provided on the microlenses **20a**, a member having high light transmittance and excellent in moisture-proof property is preferred. For example, a silicon nitride film or a silicon nitride oxide film can be used. The protective layer may be made of the same material as that of the protective layer **19** formed under the microlenses **20a** or a different material.

As described above, this embodiment satisfies Expression (5) described above in the pixel having the optical unit.

As described above, the organic light-emitting device is set under the optical interference condition with the lowest order. Therefore, light emitted with good color purity can be extracted with good color reproducibility to the outside of the display apparatus by the optical unit. Thus, the display apparatus having both high light-emission efficiency and good display performance can be realized.

Further, when the light is emitted from the organic light-emitting device at an angle equal to or larger than the critical angle corresponding to the upper limit angle at which the light is not totally reflected at the interface at which the light enters the microlens corresponding to the optical unit, the amount of extracted light is increased as compared with the amount of light extracted from the flat surface. Therefore, power consumption can be reduced. Further, the microlens having the light-condensing effect is used as the optical unit. Therefore, front luminance can be enhanced.

The exemplary embodiment of the present invention has been described above. However, the embodiment described above is an example for describing the present invention. The present invention can be carried out in various modes different from the embodiment described above without departing from the scope of the present invention. Various technologies can be used for forming the lens.

EXAMPLES

Next, the present invention is described further in detail with examples of the display apparatus and the manufacturing method therefor according to the present invention.

Example 1

Referring to FIGS. 3A to 3E, a method of manufacturing a display apparatus of Example 1 is described. First, on a glass substrate, pixel circuits (not shown) were formed by low-temperature polysilicon TFTs. An interlayer insulating film made of SiN and a planarizing film made of an acrylic resin

were formed thereon in the stated order to form the substrate **10** illustrated in FIG. 3A. An ITO film and an AlNd film were formed to thicknesses of 10 nm and 100 nm, respectively, on the substrate **10** by sputtering. Subsequently, the ITO film and the AlNd film were patterned for each pixel to form the anode electrode **11**.

An acrylic resin was spincoated thereon. Next, the acrylic resin was patterned by a photolithography technology to form an opening (opening portion corresponds to the pixel) at the position at which the anode electrode **11** was formed, thereby forming the pixel isolation layer **12**. A pitch of each pixel was set to 30 μm, and the size of an exposed portion of the anode electrode **11** by forming the opening was set to 10 μm. The pixel isolation layer **12** was subjected to ultrasonic cleaning with isopropyl alcohol (IPA), followed by boiling wash and drying. Further, after UV/ozone wash, a film made of an organic compound was grown by vacuum deposition.

First, the hole injection/transport organic compound layer **13** was grown to a thickness of 39 nm, which was common to all the pixels. A degree of vacuum at this time was 1×10^{-4} Pa, and a deposition rate was 0.2 nm/sec.

Next, a shadow mask was used to grow the hole injection/transport organic compound layer **13** to thicknesses of 18 nm and 7 nm respectively for the red-light-emitting pixels and the green-light-emitting pixels. Subsequently, for the respective light-emitting pixels, a red-light-emitting layer, a green-light-emitting layer, and a blue-light-emitting layer were grown to thicknesses of 25 nm, 20 nm, and 10 nm, respectively.

Subsequently, a film made of bathophenanthroline (Bphen) and Cs₂CO₃ was formed by co-evaporation (ratio by weight 90:10) to a thickness of 5 nm as the electron injection/transport layer common to all the pixels. A degree of vacuum at the time of evaporation was 3×10^{-4} Pa, and a film-growth rate was 0.2 nm/sec.

Next, the substrate, on which the above-mentioned organic compound layers from the hole injection/transport layer to the electron injection/transport layer were grown, was moved into a sputtering apparatus while a vacuum state was maintained. An extremely thin Ag film was formed to a thickness of 12 nm as the cathode electrode **18**.

Next, as illustrated in FIG. 3B, the protective layer **19** made of silicon nitride was grown to a thickness of 1 μm by a plasma CVD method using a SiH₄ gas, an N₂ gas, and an H₂ gas. After that, as illustrated in FIG. 3C, a thermosetting resin material (epoxy resin) having a viscosity of 3,000 mPa·s was applied under a nitrogen atmosphere at a dew-point temperature of 60° C. by using a dispenser capable of performing precise drawing (manufactured by Musashi Engineering, Inc., product name: SHOT MINI SL).

Before the thermosetting of the resin material, the mold **25** for forming the microlenses **20a**, which was prepared separately, was pressed against the surface of the resin material, as illustrated in FIG. 3D. For pressing the mold, an alignment mark formed on the mold **25** was aligned with an alignment mark formed on the substrate to perform positioning. As a result, the microlenses **20a** were formed in alignment with the pixels. Recesses were formed in the mold **25** in a concave shape at the same pitch as the pixel pitch. A surface of each of the recesses was coated with a Teflon (registered trademark) resin as a mold release agent. The shape of each of the recesses, specifically, the shape of each of the microlenses **20a** was set to have a curvature of 25.5 μm. A height of the microlens array was 10 μm for each microlens. The microlenses have the effect of improving the front luminance by 3.55 times as compared with the case where the microlens is not provided.

The planarization is achieved with the resin material even if a foreign substance or the like is present in view of the environment of a clean room and a processing apparatus. Therefore, a minimum thickness of a microlens portion **20b** (thickness at the thinnest portion) was set to 10 μm .

Heating was performed under a vacuum environment at a temperature of 100° C. for 15 minutes to cure the resin material (epoxy resin) in a state in which the mold **25** was pressed against the resin material as described above. After that, the mold **25** was released from the resin to form the microlenses **20a** as illustrated in FIG. 3E.

Characteristics of the thus manufactured display apparatus were evaluated. The optical interference conditions and light-

emission characteristics of the display apparatus of Example 1 were collectively shown in Table 5. The phase shift ϕ_1 occurring when the emitted light was reflected by the anode electrode **11** was 3.84 (rad) (220.0 degrees), and the phase shift ϕ_2 occurring when the emitted light was reflected by the cathode electrode **18** was 4.21 (rad) (241.4 degrees).

In Table 5, a cathode electrode-side order is a value of m_2 when $2L_2/\lambda + \phi_2/2\pi = m_2$ is satisfied using the optical distance L_2 , the phase shift ϕ_2 , and the maximum peak wavelength λ of the spectrum of the light emitted from the organic light-emitting device.

TABLE 5

		Red-light-emitting pixel		Green-light-emitting pixel		Blue-light-emitting pixel	
	Enhancing wavelength	620 nm		520 nm		460 nm	
Optical	Optical distance L1	121 nm		101 nm		89 nm	
interference	Anode electrode-side order	1.0		1.0		1.0	
conditions	Optical distance L2	54 nm		45 nm		28 nm	
	Cathode electrode-side order	0.8		0.8		0.8	
Film	Electron injection/transport layer			5 nm			
thickness	Light-emitting layer	25 nm		20 nm		10 nm	
	Hole injection/transport layer	18 nm		7 nm		—	
	Electron injection/transport layer			39 nm			
Refractive	Electron injection/transport layer	1.66		1.69		1.75	
index	Light-emitting layer	1.83		1.84		1.91	
	Hole injection/transport layer	1.79		1.82		1.87	
	Chromaticity CIExy	CIEx	CIEy	CIEx	CIEy	CIEx	CIEy
		0.675	0.324	0.271	0.655	0.135	0.131
	Color reproduction range			81.2%			
	Light-emission efficiency	40.1 cd/A		76.1 cd/A		10.4 cd/A	
	Power consumption			147 mW			

The chromaticity and the color reproduction range was determined through weighted averaging for a total amount of the extracted light, thus being rough standards of the chromaticity and the color reproduction range. The power consumption was determined when light emission was performed on one-third of the entire area at the luminance of 250 cd/m^2 whose chromaticity CIE xy coordinates were (0.313, 0.329) as white with a power source of 9.5 V on a diagonal 3-inch organic EL panel having an aspect ratio of 3:4 in view of the chromaticity and the efficiency.

Comparative Example 1

For a display apparatus of Comparative Example 1, the order in the optical interference condition was set to $m_1=2$ for all the light-emitting pixels in contrast to Example 1.

Characteristics of the thus manufactured display apparatus were evaluated. The optical interference conditions and the light-emission characteristics of the display apparatus of Comparative Example 1 are collectively shown in Table 6.

TABLE 6

		Red-light-emitting pixel		Green-light-emitting pixel		Blue-light-emitting pixel	
Enhancing wavelength		620 nm		520 nm		460 nm	
Optical interference conditions	Optical distance L1	431 nm		361 nm		319 nm	
	Anode electrode-side order	2.0		2.0		2.0	
	Optical distance L2	54 nm		45 nm		28 nm	
	Cathode electrode-side order	0.8		0.8		0.8	
Film thickness	Electron injection/transport layer			5 nm			
	Light-emitting layer	25 nm		20 nm		10 nm	
	Hole injection/transport layer	68 nm		27 nm		0 nm	
				162 nm			
Refractive index	Electron injection/transport layer	1.66		1.69		1.75	
	Light-emitting layer	1.83		1.84		1.91	
	Hole injection/transport layer	1.79		1.82		1.87	
Chromaticity CIE _x y		CIE _x	CIE _y	CIE _x	CIE _y	CIE _x	CIE _y
Color reproduction range		0.665	0.325	0.310	0.657	0.107	0.251
Light-emission efficiency		33.6 cd/A		66.6%		57.4 cd/A	
Power consumption				231 mW		11.9 cd/A	

As shown in Table 6, the color purity was degraded as compared with Example 1. As a result, the color reproduction range was narrowed.

Comparative Example 2

A display apparatus of Comparative Example 2 had a configuration in which the microlenses were not provided on the

protective layer 19. Otherwise, the display apparatus was manufactured in the same manner as that in Example 1.

Characteristics of the thus manufactured display apparatus were evaluated. The optical interference conditions and the light-emission characteristics of the display apparatus of Comparative Example 2 are collectively shown in Table 7.

TABLE 7

		Red-light-emitting emitting	Green-light-emitting pixel	Blue-light-emitting pixel
Enhancing wavelength		620 nm	520 nm	460 nm
Optical interference conditions	Optical distance L1	121 nm	101 nm	89 nm
	Anode electrode-side order	1.0	1.0	1.0
	Optical distance L2	54 nm	45 nm	28 nm
	Cathode electrode-side order	0.8	0.8	0.8
Film thickness	Electron injection/transport layer			5 nm
	Light-emitting layer	25 nm	20 nm	10 nm
	Hole injection/transport layer	18 nm	7 nm	0 nm
				39 nm
Refractive index	Electron injection/transport layer	1.66	1.69	1.75
	Light-emitting layer	1.83	1.84	1.91
	Hole injection/transport layer	1.79	1.82	1.87

TABLE 7-continued

	Red-light-emitting emitting		Green-light-emitting pixel		Blue-light-emitting pixel	
	CIE _x	CIE _y	CIE _x	CIE _y	CIE _x	CIE _y
Chromaticity CIE _{xy}	0.679	0.312	0.280	0.656	0.135	0.129
Color reproduction range	82.3%					
Light-emission efficiency	6.9 cd/A		28.8 cd/A		6.4 cd/A	
Power consumption	389 mW					

As shown in Table 7, the power consumption was large as compared with Example 1, which shows the effects of condensing light and increasing the light amount obtained by the microlenses of the present invention.

In comparison with Example 1, the color purity was low, and the color reproduction range was narrowed. Moreover, the power consumption was large.

Comparative Example 3

For each of the organic light-emitting devices included in a display apparatus of Comparative Example 3, the condition $m_2 > 1$ was set in contrast to Example 1. Specifically, each of the organic light-emitting devices satisfied the condition $2L_2/\lambda + \phi_2/2\pi > 1$.

Characteristics of the thus manufactured display apparatus were evaluated. The optical interference conditions and the light-emission characteristics of the display apparatus of Comparative Example 3 are collectively shown in Table 8.

Comparative Example 4

In a display apparatus of Comparative Example 4, the order corresponding to the optical interference condition of the blue-light-emitting pixel was set to $m_1 = 2$. Otherwise, the display apparatus was manufactured in the same manner as that of Example 1.

Characteristics of the thus manufactured display apparatus were evaluated. The optical interference conditions and the light-emission characteristics of the display apparatus of Comparative Example 4 are collectively shown in Table 9.

TABLE 8

		Red-light-emitting emitting		Green-light-emitting pixel		Blue-light-emitting pixel	
Enhancing wavelength		620 nm		520 nm		460 nm	
Optical interference conditions	Optical distance L1	121 nm		101 nm		89 nm	
	Anode electrode-side order	1.0		1.0		1.0	
	Optical distance L2	366 nm		343 nm		317 nm	
	Cathode electrode-side order	1.9		2.0		2.0	
Film thickness	Electron injection/transport layer			170 nm			
	Light-emitting layer	46 nm		30 nm		10 nm	
	Hole injection/transport layer	18 nm		7 nm		—	
				39 nm			
Refractive index	Electron injection/transport layer	1.66		1.69		1.75	
	Light-emitting layer	1.83		1.84		1.91	
	Hole injection/transport layer	1.79		1.82		1.87	
Chromaticity CIE _{xy}		CIE _x	CIE _y	CIE _x	CIE _y	CIE _x	CIE _y
		0.656	0.342	0.312	0.650	0.126	0.201
Color reproduction range		66.9%					
Light-emission efficiency		37.7 cd/A		68.6 cd/A		9.7 cd/A	
Power consumption		217 mW					

TABLE 9

		Red-light-emitting emitting		Green-light-emitting pixel		Blue-light-emitting pixel	
Enhancing wavelength		620 nm		520 nm		460 nm	
Optical interference conditions	Optical distance L1	121 nm		101 nm		319 nm	
	Anode electrode-side order	1.0		1.0		2.0	
Film thickness	Optical distance L2	54 nm		45 nm		28 nm	
	Cathode electrode-side order	0.8		0.8		0.8	
Refractive index	Electron injection/transport layer			5 nm			
	Light-emitting layer	25 nm		20 nm		10 nm	
	Hole injection/transport layer	18 nm		7 nm		123 nm	
Chromaticity CIE _x y	Electron injection/transport layer	1.66		1.69		1.75	
	Light-emitting layer	1.83		1.84		1.91	
	Hole injection/transport layer	1.79		1.82		1.87	
Color reproduction range		CIE _x	CIE _y	CIE _x	CIE _y	CIE _x	CIE _y
Light-emission efficiency		0.675	0.324	0.271	0.655	0.110	0.240
Power consumption		40.1 cd/A		76.1 cd/A		14.1 cd/A	
				69.9%		185 mW	

In comparison with Example 1, the color purity was low, and the color reproduction range was narrowed. Moreover, the power consumption was large.

Comparative Example 5

For a display apparatus of Comparative Example 5, the condition $m_2=1$ was set in contrast to Example 1. Specifically,

each of the organic light-emitting devices satisfied the condition $2L_2/\lambda + \phi_2/2\pi = 1$.

Characteristics of the thus manufactured display apparatus were evaluated. The optical interference conditions and the light-emission characteristics of the display apparatus of Comparative Example 5 are collectively shown in Table 10.

TABLE 10

		Red-light-emitting emitting		Green-light-emitting pixel		Blue-light-emitting pixel	
Enhancing wavelength		620 nm		520 nm		460 nm	
Optical interference conditions	Optical distance L1	121 nm		101 nm		89 nm	
	Anode electrode-side order	1.0		1.0		1.0	
Film thickness	Optical distance L2	109 nm		92 nm		76 nm	
	Cathode electrode-side order	1.0		1.0		1.0	
Refractive index	Electron injection/transport layer			32 nm			
	Light-emitting layer	30 nm		20 nm		10 nm	
	Hole injection/transport layer	18 nm		7 nm		—	
Chromaticity CIE _x y	Electron injection/transport layer	1.66		1.69		1.75	
	Light-emitting layer	1.83		1.84		1.91	
	Hole injection/transport layer	1.79		1.82		1.87	
Color reproduction range		CIE _x	CIE _y	CIE _x	CIE _y	CIE _x	CIE _y
Light-emission efficiency		0.660	0.337	0.295	0.651	0.132	0.156
Power consumption		40.8 cd/A		77.3 cd/A		12.0 cd/A	
				73.4%		152 mW	

In comparison with Example 1, the color purity was low, and the color reproduction range was narrowed. Moreover, the power consumption was large.

The display apparatus according to the present invention can be applied to mobile uses for which the improvement of visibility by high luminance is important, for example, a rear monitor of a digital camera and a cellular phone display. In addition, lower power consumption is expected even at the same luminance. Therefore, the display apparatus of the present invention is also useful for outdoor uses.

While the present invention has been described with reference to exemplary embodiments, it is to be understood that the invention is not limited to the disclosed exemplary embodiments. The scope of the following claims is to be accorded the broadest interpretation so as to encompass all such modifications and equivalent structures and functions.

REFERENCE SIGNS LIST

- 10 substrate
- 11 anode electrode
- 13 hole injection/transport organic compound layer
- 14 light-emitting layer showing red light emission (pattern layer for each color including red-light-emitting layer)
- 15 light-emitting layer showing green light emission (pattern layer for each color including green-light-emitting layer)
- 16 light-emitting layer showing blue light emission (pattern layer for each color including blue-light-emitting layer)
- 17 electron injection/transport organic compound layer
- 18 cathode electrode
- 20a microlens

This application claims the benefit of Japanese Patent Application Nos. 2010-266660, filed Nov. 30, 2010, and 2011-238493, filed Oct. 31, 2011, which are hereby incorporated by reference herein in their entirety.

What is claimed is:

1. A display apparatus, comprising multiple pixels, each of the multiple pixels comprising an organic light-emitting device comprising a first electrode, a light-emitting layer, and a second electrode,
- the multiple pixels comprising an optical unit for allowing a part of light emitted from the organic light-emitting device to exit to outside while changing an exiting direction thereof,
- wherein, in the multiple pixels, an optical distance L_1 between a light-emission position of the organic light-emitting device and the first electrode and an optical distance L_2 between the light-emission position and the second electrode satisfy Expressions below:

$$2L_1/\lambda + \phi_1/2\pi = 1; \text{ and}$$

$$L_2 > 0, \text{ and } 2L_2/\lambda + \phi_2/2\pi < 1,$$

where λ is a maximum peak wavelength of a spectrum of light emitted from the organic light-emitting device, ϕ_1 is a phase shift occurring when the light emitted at the light-emission position is reflected by the first electrode, and ϕ_2 is a phase shift occurring when the light emitted at the light-emission position is reflected by the second electrode.

2. The display apparatus according to claim 1, wherein the optical unit extracts light entering the optical unit at an angle of 30 degrees or larger.

3. The display apparatus according to claim 1, wherein the optical unit comprises a lens having a light-condensing effect.

* * * * *

专利名称(译)	显示装置		
公开(公告)号	US8729789	公开(公告)日	2014-05-20
申请号	US13/295429	申请日	2011-11-14
[标]申请(专利权)人(译)	佳能株式会社		
申请(专利权)人(译)	佳能株式会社		
当前申请(专利权)人(译)	佳能株式会社		
[标]发明人	HASEGAWA TOSHINORI		
发明人	HASEGAWA, TOSHINORI		
IPC分类号	H01L51/50		
CPC分类号	H01L51/5265 H01L27/3211 H01L51/5275		
优先权	2010266660 2010-11-30 JP 2011238493 2011-10-31 JP		
其他公开文献	US20120133575A1		
外部链接	Espacenet USPTO		

摘要(译)

提供一种显示装置，其具有高发光效率和良好的显示性能。显示装置包括多个像素，多个像素中的每一个包括有机发光装置，有机发光装置包括第一电极，发光层和第二电极，多个像素包括用于允许从其发出的光的一部分的光学单元。发光层在改变其出射方向的同时离开外部，其中，在包括光学单元的多个像素中，发光层与第一电极之间的光学距离或发光之间的光学距离将第二电极和第二电极设定为预定值。

